

NT-USB MINI

STUDIO-QUALITY USB MICROPHONE

The NT-USB Mini is a compact, studio-quality USB microphone designed for recording direct to a computer or tablet. It is simple to set-up and use, and a smooth frequency response and directional pickup pattern make the NT-USB Mini perfect for recording vocals and instruments, livestreaming and gaming, podcasting, voice calls and more. The included desk stand features a magnetic base that can be detached for easy mounting on mic stands or studio arms, and with its in-built pop filter and zero-latency headphone monitoring, the NT-USB Mini delivers crisp, clear audio in all recording applications.

- Studio-quality microphone with USB-C connectivity
- 3.5mm headphone output with zero-latency monitoring
- Easy set-up, plug in and play
- Detachable magnetic desk stand
- In-built pop filter

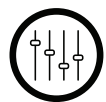

STUDIO QUALITY



HEADPHONE OUTPUT JACK



USB AUDIO COMPATIBLE



DETACHABLE DESK STAND



INTERNAL POP FILTER



ACOUSTIC & ELECTRICAL SPECIFICATIONS

Acoustic Principle:	Pressure gradient
Active Electronics:	Electret condenser, A/D and USB interface
Polar Pattern:	Cardioid
Frequency Response:	20Hz - 20kHz
Max SPL:	121dB (1% THD)
Sample Rate:	48 kHz
Bus Powered:	Yes
Bit Depth:	24-bit
Analog Output:	3.5mm headphone
Computer Connectivity:	USB - simultaneous I/O Mono input, stereo output
Output Connection:	USB-C
Minimum OS Requirement:	macOS 10.12 Windows 10



MECHANICAL SPECIFICATIONS

Weight (grams):	585
Dimensions (millimetres):	Width: 54.5 Height: 141.9 Diameter (base): 89.3
Compatible RØDE Accessories:	PSA1+, PSA1, SC17, SC18, COLORS, DS1, Tripod 2
Included Accessories:	1 x NT-USB Mini 1 x SC20 1 x Thread Mount Adaptor

WHAT'S IN THE BOX



NT-USB Mini



SC20



Thread Mount Adaptor

DIMENSIONS

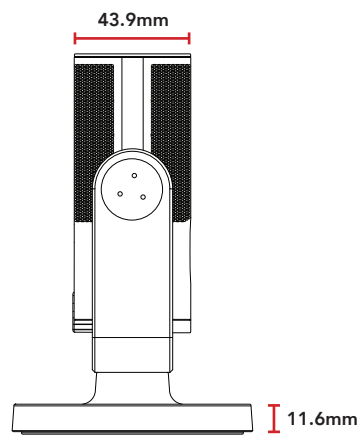
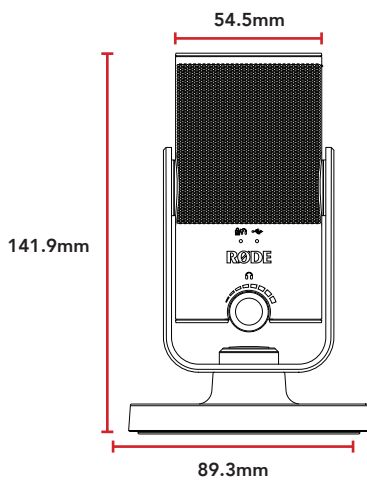

POLAR PATTERN

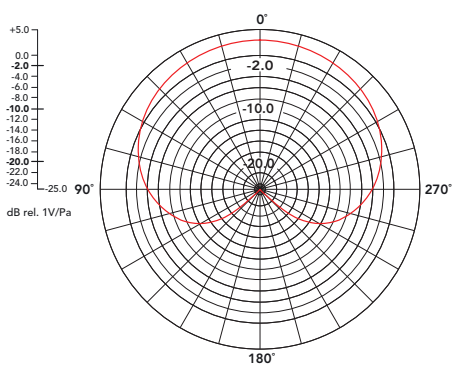

FREQUENCY RESPONSE

